

# IEEE 802.11n MAC Enhancement and Performance Evaluation

Chih-Yu Wang · Hung-Yu Wei

Published online: 9 January 2009  
© Springer Science + Business Media, LLC 2008

**Abstract** The IEEE 802.11-based WiFi wireless technology is one of the most promising technologies to provide ubiquitous networking access. The IEEE 802.11 working group has always strived to improve this wireless technology through creating new amendments to the base 802.11 standard. Recently, IEEE 802.11n amendment was created to enhance 802.11 for higher throughput operation. Not only new Physical Layer enhancements are standardized, but new Medium Access Control Layer mechanism are also defined. In this paper, we examine the network performance enhancement by the proposed 802.11n MAC layer features: aggregation, block acknowledgement, and reverse direction mechanism. We implemented a new 802.11n module in the NS-2 simulation platform. The simulation results demonstrated the effectiveness of 802.11n MAC layer enhancement. VoIP performance is effectively improved with 802.11n MAC enhancement.

**Keywords** IEEE 802.11n · performance evaluation · ns-2 · VoIP

## 1 Introduction

IEEE 802.11-based WiFi system is one of the most widely deployed wireless access technologies around the world. With the wide spreading of IEEE 802.11 wireless devices, providing Quality of Service for var-

ious mobile wireless networking applications has become a critical issue. The IEEE 802.11e amendment is proposed to enhance MAC layer Quality of Service. Recently, the IEEE 802.11 working group has been in the stage of finalizing the 802.11n standard. IEEE 802.11n aims to provide higher throughput to provide better wireless access support for the increasing demand of the application bandwidth requirements. To achieve higher throughput and better spectral efficiency, not only improvement of the physical layer communications design but also MAC layer enhancement are needed. In this paper, we will examine the enhanced MAC layer design in the IEEE 802.11n systems.

The main contribution of this work is to provide a systematic understanding of the three IEEE 802.11n MAC layer major enhanced mechanisms: aggregation, block acknowledgement, and reverse direction. Most previous works on IEEE 802.11n performance evaluation only explored aggregation mechanism [8, 15, 18]. Moreover, most of these works focus on the enhanced throughput. Our evaluation further examines the influence of different aggregation limits with the block acknowledgement mechanism and the impact on packet delay time. We also give a detailed discussion and evaluate the block acknowledgement mechanism in the 802.11n context. Performance evaluation on MAC layer enhancement of IEEE 802.11n in terms of channel efficiency has been discussed by TGn [16]. In contrast, we look at the performance metrics, including delay and jitter of packets. We also investigate the application performance over 802.11n. We evaluate IEEE 802.11n MAC layer enhancement through an integrated approach to analyze all MAC layer enhancements including aggregation, block acknowledgement, and reverse direction mechanism. A realistic 802.11n

---

C.-Y. Wang · H.-Y. Wei (✉)  
Department of Electrical Engineering,  
National Taiwan University, Taipei,  
Taiwan, Republic of China  
e-mail: hywei@cc.ee.ntu.edu.tw

network simulation module is implemented. We have analyzed the performance and design trade-offs among the three enhanced MAC mechanisms. The performance of VoIP under IEEE 802.11n has been investigated. Cai *et al.* analyzed VoIP capacity under 802.11n [2]. Ozdemir *et al.* evaluated the performance of the VoIP packet loss rate and throughput through simulation [12]. Liu *et al.* investigated the integration of AC prioritization and the aggregation mechanism on delay sensitive applications [9]. Our investigation of the service quality of VoIP over IEEE 802.11n addresses a broader discussion on the impact of three 802.11n MAC mechanisms. We also studied the application layer VoIP performance with R-Score [5] as well as wireless network statistics.

## 2 IEEE 802.11

### 2.1 Legacy 802.11 MAC operation

Before addressing the higher throughput enhancement in MAC, we first briefly discuss the overhead in the legacy IEEE 802.11 MAC protocol operation. The widely used distributed coordination function (DCF) is a distributed channel access mechanism based on CSMA/CA (Carrier Sense Multiple Access with Collision Avoidance). A successful packet transmission in DCF is illustrated in Fig. 1. Optional RTS/CTS (Request To Send/Clear To Send) mechanism could be along with the CSMA/CA channel contention mechanism. Typically, the default setting for RTS/CTS operation in current WiFi network interface cards is off. When a station has a data frame (MAC service data unit, MSDU) to transmit, MAC headers are added to form MPDUs. The station waits a fixed time interval called DCF interframe space (DIFS) before transmission.

When MAC finds an idle channel, it enters a backoff procedure with a backoff timer, which is determined randomly by the contention window (CW). If the chan-

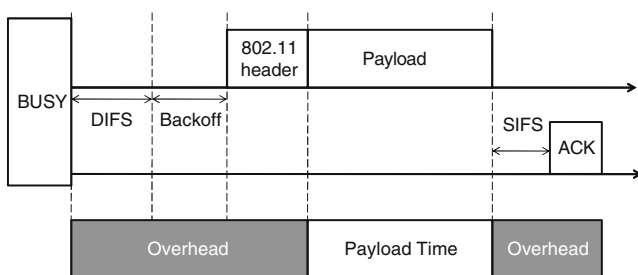

**Fig. 1** Legacy IEEE 802.11 operation

nel is still idle during and after the backoff procedure, the station immediately accesses the channel. The station which successfully received the MSDU should send an acknowledge (ACK) frame back to the sending station. A short interframe space (SIFS) waiting time is applied before replying the ACK message. The whole transmission procedure ends when the sending station successfully receives the ACK frame.

By looking into the procedure of a packet transmission, we note that DCF is inefficient in channel utilization. During the transmission procedure, transmission time is divided into a DIFS, a Contention Window backoff time, the PPDU transmission time, a SIFS, and the ACK frame transmission time. The PPDU transmission time can be further divided into two parts: 802.11 header and data payload transmission time. Other than the payload transmission portion is the overhead. The overhead of the DCF mechanism results in the inefficiency of the channel utilization, and thus limits the data throughput. When the payload is small, the overhead is relatively large and is less efficient. The percentage of the overhead among all usable airtime increases as the physical transmission rate increases. The overhead limits the achievable data throughput. In the higher data rate scenario, although the frame transmission time is reduced, the other part of the overhead is unchanged due to the backward compatibility issue. As a result, to achieve higher throughput in 802.11, reducing the percentage of overhead is critical.

### 2.2 IEEE 802.11e enhancement

The major enhancement in IEEE 802.11e MAC protocol [10] is providing Quality of Service (QoS), which is lacking in the legacy IEEE 802.11 MAC protocol. In IEEE 802.11e, enhanced distributed channel access (EDCA) is introduced to enhance legacy IEEE 802.11 DCF operation. EDCA is a contention-based channel access mechanism. The support of QoS is provided with access categories (ACs). Four ACs are used in EDCA, each with an independent backoff mechanism and contention parameters. The parameters of ACs are set differently to provide differentiated QoS priorities for ACs.

An important breakthrough in the IEEE 802.11e MAC mechanism is the introduction of transmission opportunity (TXOP). TXOP mechanism defines a period of time for a station accessing the channel to transmit multiple data frames. During a TXOP period, the station can transmit multiple data frames without

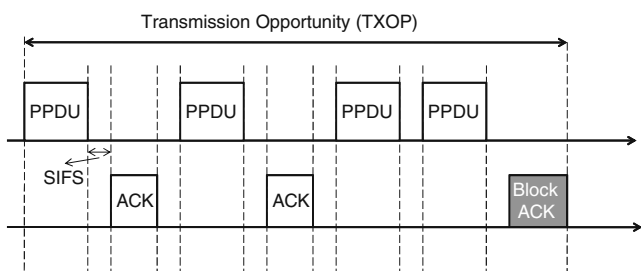

**Fig. 2** IEEE 802.11e TXOP and block ACK

entering backoff procedure, which reduces the overhead due to contention and backoff and thus enhances the efficiency of channel utilization. A TXOP period can be obtained through a successful contention in EDCA.

In pair with TXOP, the block acknowledgment (block ACK) mechanism can be used to further enhance the channel utilization efficiency. A station transmitting multiple data frames in TXOP can request one block ACK for all these frames instead of using legacy acknowledgments to each frame, and the resource of transmitting multiple acknowledgements and interframe spaces SIFSs is saved, as shown in Fig. 2. A performance analysis on block ACK mechanism in 802.11e has been studied in [7]. Simulations are conducted to validate the proposed Markov Chain performance model. In addition, three types of analytical performance models have been investigated [13]. Simulations are used to compare the validity of these three models.

### 3 Next generation WiFi: IEEE 802.11n

Although 802.11e adds the support of QoS, TXOP and block ACK, the inefficiency of channel utilization in legacy 802.11 MAC is not fully solved. To satisfy the need of the high-speed wireless network access today, the major target of IEEE 802.11n, which is next-generation WLAN standard under development, is to provide high throughput mechanism based on state-of-art design while allowing the coexistence of legacy 802.11 devices. To meet the requirements of “high throughput”, two possible methods can be applied. One is increasing the data rate in the physical layer (PHY layer), and the other is increasing the efficiency in the medium access layer (MAC layer). Based on the foundation of 802.11a/b/g/e, numerous new features in PHY and MAC layers are introduced to enhance the throughput of IEEE 802.11 WLAN.

#### 3.1 MIMO-OFDM physical layer

To achieve high throughput in 802.11 wireless networks, the most commonly used method is to increase the raw data rate in the PHY layer. Legacy 802.11 PHY layer uses single-input single-output (SISO) system in 20 MHz bandwidth channel with one antenna. This design is not capable to meet the high data rate requirements because of low spectral efficiency of SISO and the limited bandwidth. Although in 802.11a/g, orthogonal frequency division multiplexing (OFDM) transmission scheme has been used to increase PHY layer transmission rate to 54 Mbps, the underlying spectral inefficiency issue is unsolved. IEEE 802.11n expands the channel bandwidth to 40MHz to increase the channel capacity, and operates in OFDM scheme with the multi-input multi-output [6] (MIMO) technique. MIMO can effectively enhance spectral efficiency with simultaneously multiple data stream transmissions. In theory, channel capacity gain could be up to the number of antenna used in transmission without additional bandwidth or power [6]. The power of the MIMO system relies on using space-time coding and the channel information for intelligent transmission. Multiple antennas could help transmitting and receiving from multiple spatial channels simultaneously. Multipath wireless fading channel results in poor performance in legacy 802.11 PHY scheme. Hence, 802.11n PHY applies MIMO technique to improve performance over multipath environment. The 802.11n PHY applies LDPC and STBC [3] for MIMO-OFDM communications. With this enhancement in the PHY layer, the peak PHY rate can be boosted up to 600 Mbps to meet the IEEE 802.11n high throughput requirement.

#### 3.2 Aggregation

Aggregation mechanism is the key feature to improve the 802.11 MAC transmission efficiency. We have described the overhead in legacy IEEE 802.11 MAC which has been partly solved by 802.11e with TXOP. Aggregation can further enhance efficiency and channel utilization. The aggregation mechanism combines multiple data packets from the upper layer into one larger aggregated data frame for transmission. Overhead in multiple frame transmissions is reduced since the header overhead and interframe time is saved. Aggregation scheme achieves higher system gain for application scenarios with small packets, for example, VoIP.

In IEEE 802.11n MAC, the aggregation mechanism is designed as two-level aggregation scheme [18]. Two types of aggregation frame are defined: aggregate MAC

protocol service unit (A-MSDU) and aggregate MAC protocol data unit (A-MPDU). The aggregation mechanism can function with A-MPDU, A-MSDU, or using both of them to form two-level aggregation. A-MSDU is composed with multiple MSDUs and is created when MSDUs are received by the MAC layer. For ease in the de-aggregation process, the size of MSDU, including its own subframe header and padding, must be a multiple of 4 bytes. Two parameters are used for forming A-MSDUs: the maximum length of an A-MSDU, 3839 or 7935 bytes by default, and the maximum waiting time before creating an A-MSDU. These MSDUs must be in the same traffic flow (same TID) with the same destination and source. Broadcasting and multicasting packets are excluded.

In the second level, multiple MPDUs are aggregated into an A-MPDU. A-MPDUs are created before sending to PHY layer for transmission. Unlike the A-MSDU creation, MAC does not wait for additional time before the A-MPDU aggregation. MAC only use the MPDUs already in the queue upon creating A-MPDUs. The TID of each MPDU in the same A-MPDU might be different. The maximum size limit of A-MPDU is 65535 bytes. In A-MPDU, each MPDU has an MPDU delimiter at the beginning and padding bytes at the end. These bytes ensure that the size of each MPDU is the multiple of 4 bytes. Delimiter is used to separate MPDUs in an A-MPDU. The de-aggregation process first checks the CRC integrity. If the CRC check is passed, the MPDU will be de-aggregated and sent to upper layer.

The two-level aggregation mechanism is shown in Fig. 3. In the first level, MSDUs received by MAC from the upper layer are buffered for a short time until A-MSDUs are formed according to their TID, destina-

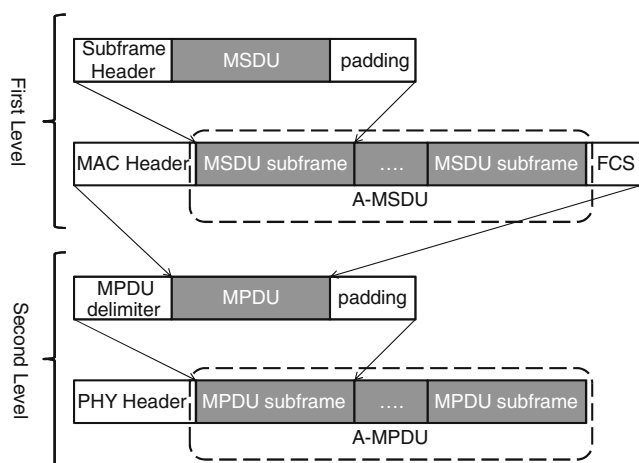

Fig. 3 Two-level aggregation in IEEE 802.11n

tion, source, and the maximum size of A-MSDU. The complete A-MSDUs and other non-aggregate MSDUs then enter the second level to form an A-MPDU. For compatibility reason, every MPDU in A-MPDU should not exceed 4095 bytes. Note, 802.11n aggregation does not support frame fragmentation. Only complete A-MSDUs or MSDUs, not the fragments of A-MSDUs or MSDUs, could be contained in an A-MPDU. The whole aggregation mechanism completes when A-MPDU is created.

### 3.3 Block ACK

Originally, the block ACK operation incorporates the TXOP mechanism, as previously described in the 802.11e MAC design. The block ACK mechanism is further enhanced in 802.11n to be applied with the aggregation feature. Although a larger aggregation frame can significantly reduce the overhead in transmission, the frame error rate is higher as the size of the frame increases. Large frames in high bit-error-rate (BER) wireless environment have a higher error probability and may need more retransmission. The network performance might be degraded. To overcome this drawback in aggregation, the block ACK mechanism in 802.11n is modified to support multiple MPDUs in an A-MPDU. When an A-MPDU from one station is received and errors are found in some of the aggregated MPDUs, the receiving node sends a block ACK only acknowledging those correct MPDUs. The sender only needs to retransmit those non-acknowledged MPDUs. Block ACK mechanism resolves the drawback of large aggregation in the error-prone wireless environment and further enhances the performance of 802.11n MAC (Fig. 4).

Note, block ACK mechanism only applies to A-MPDU, but not A-MSDU. That is, when an MSDU is found to be incorrect, the whole A-MSDU needs to be transmitted for error recovery. The maximum number of MPDUs in an A-MPDU is limited to 64 as one block

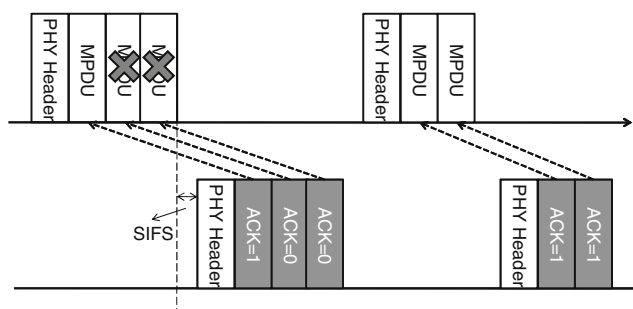

Fig. 4 Block ACK with aggregation

ACK bitmap can only acknowledge at most 64. The original block ACK message in IEEE 802.11e contains a Block ACK bitmap field with  $64 \times 2$  bytes. These two bytes record the fragment number of the MSDUs to be acknowledged. However, fragmentation of MSDU is not allowed in 802.11n A-MPDU. Thus, those 2 bytes can be reduced to 1 byte, and the block ACK bitmap is compressed to 64 bytes. This is known as compressed block ACK. Compared with 802.11e, the overhead of block ACK bitmap in 802.11n is reduced.

### 3.4 Reverse direction

Reverse direction mechanism is a novel breakthrough to enhance the efficiency of TXOP. In conventional TXOP operation, the transmission is uni-directional from the station holding the TXOP, which is not applicable in some network services with bi-directional traffic like VoIP and on-line gaming. The conventional TXOP operation only helps the forward direction transmission but not the reverse direction transmission. For application with bi-directional traffic, their performance degrades by the random backoff and contention of the TXOP transmission opportunities. Reverse direction mechanism allows the holder of TXOP to allocate the unused TXOP time to its receivers to enhance the channel utilization and performance of reverse direction traffic flows.

The reverse direction operation is illustrated in Fig. 5. In reverse direction operation, two types of stations are defined: RD initiator and RD responder. RD initiator is the station which holds the TXOP and has the right to send Reverse Direction Grant (RDG) to the RD responder. RDG is marked in the 802.11n header and is sent with the data frame to the RD responder. When the RD responder receives the data frame with RDG, it responds with RDG acknowledgement if it has data to be sent, or without RDG if there is no data to be sent to the RD initiator. If

the acknowledgement is marked with RDG, the RD initiator will wait for the transmission from the RD responder, which will start with SIFS or Reduced Inter-Frame Spacing (RIFS) interframe time after the RDG acknowledgement is sent. RIFS can be used in the scheme when no packet is expected to be received after transmission, which is the case here. If there is still data to be sent from the RD responder, it can mark RDG (which represents MORE DATA here) in the data frame header to notify the initiator. The RD initiator still has the right to accept the request. To allocate the remaining TXOP, the initiator will mark the RDG in the acknowledge message or the next data frame. To reject the new RDG request, the initiator just ignores it.

The major enhancement in reverse direction mechanism is the delay time reduction in reverse link traffic. These reverse direction data packets do not need to wait in queue until the station holds TXOP but can be transmitted immediately when the RD responder is allocated for the remaining TXOP. This feature can benefit a delay-sensitive service like VoIP, which we will show a performance enhancement in the simulation section.

## 4 Simulation module implementation

We implement an IEEE 802.11n MAC and PHY module in Network Simulator 2 (NS-2) platform [11]. NS-2 is a commonly used open-source network simulator. Our implementation is based on TKN 802.11e EDCA module [17]. The TKN module is modified based on the legacy 802.11 MAC module in NS-2 2.28, and provides EDCA, TXOP, and Access Categories (ACs) support in 802.11e. To fully support these mechanisms, each AC has its own group of timers to handle the events in the AC and share the same and only PHY interface. The interval collision issue is simulated in this module. The TXOP mechanism is implemented with Contention Free Burst functions. A dynamically-allocated contention free burst period is defined within transmissions. The module is designed to be compatible with the original NS-2 802.11 model. Since the default NS-2 802.11 PHY is a simplified model, we create an enhanced PHY for our simulation. In PHY layer, based on the previous research work in 802.11n PHY [4], we implemented the SNR-BER table to simulate the network performance and error recovery efficiency under different MIMO system schemes and power constraints.

We focus on the implementation of MAC layer to reflect the enhancement on channel utilization from MAC layer. We only implement A-MPDU to

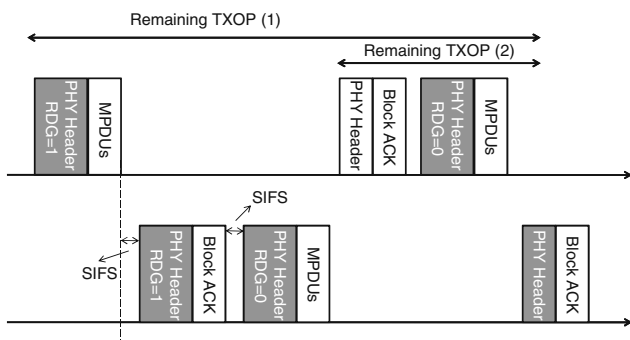

**Fig. 5** Reverse direction

simplify the implementation of aggregation. This simplified mechanism has been studied [15] and the simulation results show the aggregation without A-MSDU only has little degradation in performance. Block ACK mechanism is also implemented. The block ACK module could work with or without the aggregation mechanism. Moreover, reverse direction mechanism is implemented independently from aggregation and block ACK mechanism. In the next section we will investigate the performance of 802.11n based on the NS-2 simulation results.

A detailed structure of our implementation is shown in Fig. 6. MAC802\_11N class is the core of our 802.11n model, which is based on MAC802\_11E class in TKN module. The support of aggregation and de-aggregation mechanism is realized with modified Packet class in NS-2 to accommodate multiple packets. Block ACK mechanism is implemented based on the original 802.11 ACK module with the necessary changes. The additional block ACK bitmap is attached as a packet data array in the block ACK packet. Block ACK mechanism coexists with the original ACK. To implement the reverse direction mechanism, we design a new state flow in MAC802\_11N for allowing the holder of TXOP allocate its TXOP to others.

We also modify the Queue class in TKN module to support aggregation and reverse direction mechanism. MIMO Physical Layer is implemented in a new MIMO class, which is modified from the WirelessPhy class in NS-2. When a packet is transmitted, MIMO system BER of the packet is calculated according to SNR-BER table in [4]. Based on the BER, we randomly decide

if the packet contains error bits. If the packet is an aggregated A-MPDU, errors in each MPDU packet is generated independently.

### 5 Simulation results

In our simulation, several different scenarios are designed to examine the performance of each enhanced MAC feature in 802.11n. The default values of simulation parameters are shown in Table 1.

The peak PHY transmission rate is set to 96 Mbps [4]. The default size of maximum allowable aggregation is set to 16383 bytes so that no oversized aggregation will be created to cause problems when simulating aggregation along with TXOP or reverse direction operations. The network contains number of stations in a small 500 × 500 m open area and all stations are within their transmission range as well as interference range. Optional RTS-CTS mechanism is off as the usual case in typical 802.11 products. Although the network traffic loads differ in each scenario, in principle we apply CBR traffic to keep the total network throughput in saturation condition in order to examine 802.11n performance in critical wireless networking scenarios.

#### 5.1 Aggregation enhancement

To study the enhancement of aggregation mechanism, we control the aggregation limit in order to control the size of A-MPDU. To study the influence of aggregation limit settings on network performance, we examine two important measurements in a network: throughput and packet delay time. We create four 51.2 Mbps constant-bit-rate (CBR) traffic flows, each with packet size 512 bytes and 80 μs inter-arrival time. We adjust their aggregation limit from 0 (which means aggregation feature is off) to 65535 bytes (default 802.11n A-MPDU aggregation limit) and measure the throughput and average packet delay time in each scheme. The results are shown in Fig. 7. The total throughput

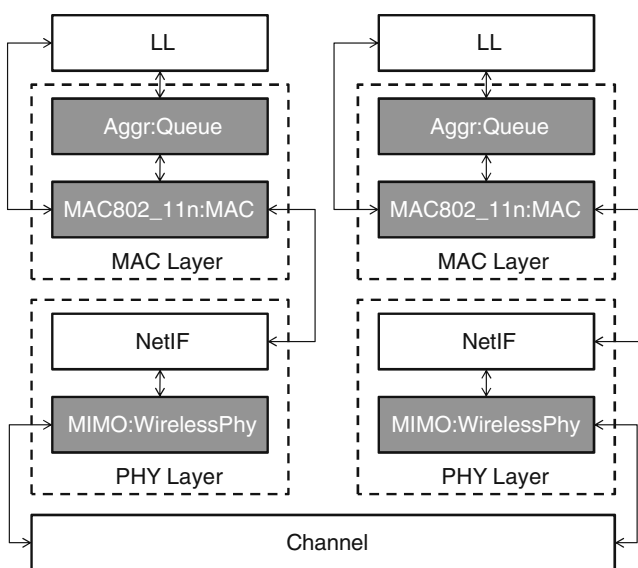
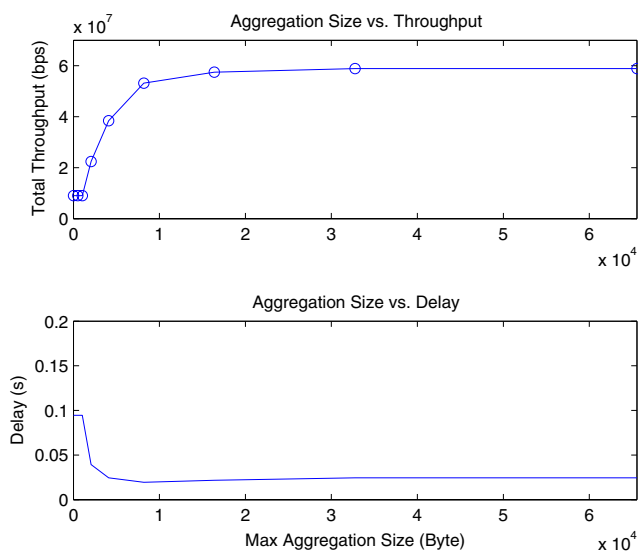

Fig. 6 NS-2 implementation

Table 1 Default parameter settings in simulation

Parameter	Value
Slot time	20 μs
SIFS	10 μs
TXOP limit	3.264 ms
Queue limit	70
Aggregation limit	16383 bytes
Bandwidth	96 Mbps
Bit error rate	0.000008
Area	500 × 500 m



**Fig. 7** Aggregation size

increases with the aggregation limit. The total throughput is saturated to 59 Mbps, which corresponds to channel efficiency of 61.5%. Even though channel efficiency improves with the aggregation scheme, there are still unavoidable frame header and interframe space. As we observed, the aggregation limit is an important factor to determine the total throughput of wireless network in saturation condition. As shown in Fig. 7, the total throughput is saturated when the aggregation limit is more than 16383 bytes in our network scenario (4 stations). In the future simulations, we will set the maximum aggregation limit to 16383 bytes.

We also observed that when aggregation feature is on, the average packet delay time decreases rapidly. The reason is that multiple packets can be received at once and the overhead in backoff mechanism and additional header transmission is reduced. With 802.11n aggregation, the reduce delay time benefits delay-sensitive services, such as VoIP. We will discuss the performance of VoIP next.

In another simulation scenario with different bit-error rate setting, we observed that the enhancement from aggregation is greatly affected by the BER. We will discuss the effect in Section 5.3.

## 5.2 VoIP R-score vs. background traffic

To further evaluate the enhancement of aggregation, we examine the quality of VoIP service over 802.11n aggregation with background traffic. We choose a widely used VoIP quality measurement R-score [5]

for evaluation. R-score ranges from 100 (Best) to 0 (Worst), which is calculated by data loss rate, delay time, and coding efficiency. R-score over 70 is considered as acceptable quality. R-score can give us a practical view of the enhancement on delay time and packet loss rate in IEEE 802.11n.

We create 4 pairs of VoIP users communicating with G.711 voice codec (64kbps with packet size of 160 bytes). RTP over UDP is used to carry VoIP traffic. Meanwhile, each user has background CBR traffic with 0.04 s interval time. We will adjust the background data traffic rate from 80 to 512 kbps. As the main goal of this study is to investigate the 802.11n MAC enhancement, we use the same AC for all traffic flows.

R-score performance of VoIP service with and without aggregation are shown in Fig. 8. Although the background traffic is relatively small compared to the peak PHY rate, the R-score in the scheme without aggregation decreases significantly as the traffic load increases. The reason is that frames collide during transmission and increased number of packets waiting in queue dropped. This leads to large loss rate and long delay time. In contrast, we observe that R-score is almost unaffected in the scheme with aggregation because of the increased network throughput with the help of aggregation. The number of packets dropped by queue or lost in collision decreases with the aggregated A-MPDU, which can transmit large number of small packets at once. What is more, the overhead including packet headers and interframe time is also reduced; thus, the delay time of each packet decreases as shown in Fig. 7. The improvement of these two factors results in the high R-score and stable quality of VoIP service.

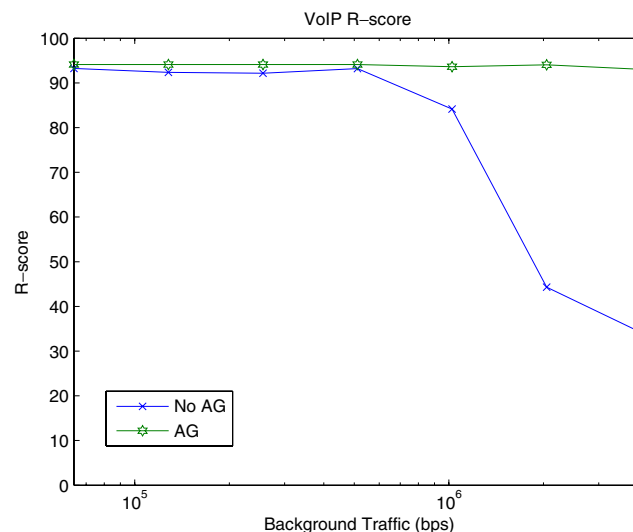

**Fig. 8** VoIP R-score

### 5.3 Block ACK vs. BER

After examining the aggregation performance, we evaluate the block ACK feature. BER (Bit-Error Rate) condition is a major factor on the performance error recovery efficiency of block ACK. We use the same simulation settings except setting the aggregation limit to 16384 bytes. Each CBR traffic flow has the rate of 51.2 Mbps. As data packet size might affect the system performance, we adjust the data packet size in various scenarios. We keep the data rate to a constant value while adjusting the data packet size and transmission interval accordingly. We adjust the packet size from 64 to 2048 bytes. In this scheme we compare three different MAC mechanisms: legacy 802.11 MAC without Aggregation (No AG), 802.11n Aggregation without Block ACK (AG, No BA), and 802.11n Aggregation with Block ACK (AG, BA). We evaluate the mechanisms in a low BER and a high BER scenario. The simulation results are shown in Figs. 9 and 10 respectively.

We can find that the performance of aggregation and block ACK depends on BER significantly. When BER is  $8 \times 10^{-6}$ , both schemes with aggregation can improve the total throughput, compared to legacy 802.11. However, the 802.11n aggregation mechanism without block ACK outperforms the mechanism with block ACK with additional 5% throughput. This is because the size of block ACK packet is larger than legacy acknowledgement packet by 64 bytes. When BER is low, the error recovery happens less frequently, and the extra size of block ACK cannot be neglected.

In contrast, when  $BER = 2.05 \times 10^{-4}$  we can see the drawback of aggregation shows up in the mechanism

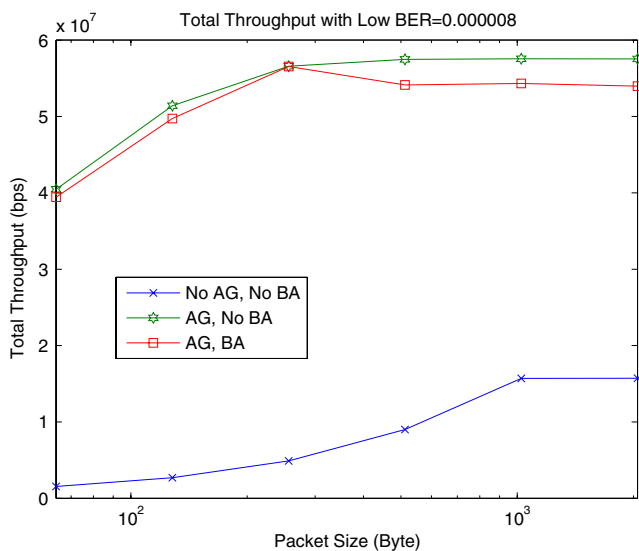

Fig. 9 Block ACK performance in Low BER environment

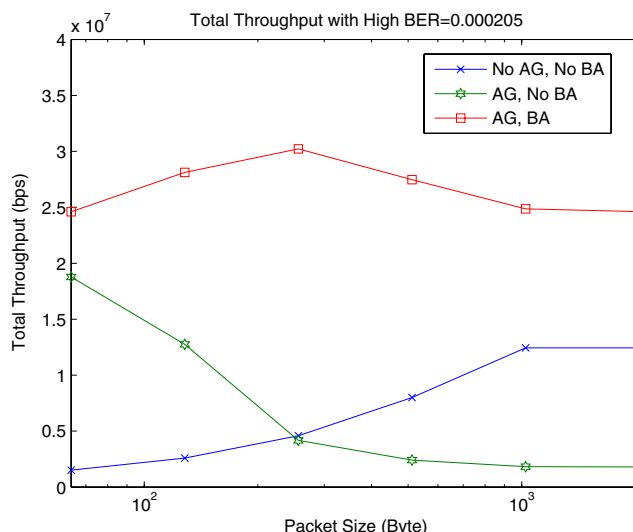

Fig. 10 Block ACK performance in High BER environment

of aggregation without block ACK, which has poor performance even lower than legacy 802.11 MAC. This is because aggregation creates larger A-MPDU, which is more likely to have error and need retransmission. Without block ACK mechanism, errors can only be recovered by retransmitting the whole A-MPDU again. With block ACK, error recovery can be realized in a more efficiency way by only retransmitting the MPDUs with errors. The performance of 802.11n aggregation with block ACK is less damaged by high BER and keeps a greater throughput than both legacy 802.11 and 802.11n aggregation without block ACK.

We conclude that although block ACK mechanism introduces additional overhead than legacy acknowledgement, it is still a necessary mechanism to be applied with aggregation in wireless network. The efficient error recovery ability of block ACK can alleviate the drawback of aggregation in high BER environment.

### 5.4 Reverse direction enhancement

We create bi-directional traffic scenarios to examine the performance of TXOP and reverse direction mechanism. There are two access stations: STA A, and STA B. STA A serves two mobile stations MS A1 and MS A2. STA B serves only one mobile station MS B1. Each MS has one uplink CBR traffic flow to and one downlink CBR traffic from the station it connects to. With the combination of each access station runs with or without the reverse direction mechanism, we have 4 different schemes to evaluate.

1. Both STA A and STA B are without RD.
2. STA A with RD, while STA B without RD.



3. STA B with RD, while STA A without RD.
4. Both STA A and STA B are with RD.

We simulate these 4 schemes respectively and measure the receiving throughput of each access station and mobile user. We set the background CBR traffic to 25.6 Mbps and set aggregation limit to 4095 bytes. The results are shown in Fig. 11.

Comparing scheme 1 and scheme 2, we observe that reverse direction mechanism indeed enhances the receiving throughput of STA A. The amount of increased throughput fits the decreased amount of receiving throughput of MS A1 and A2. We have the same observation by comparing scheme 1 and scheme 3. Based on the reverse direction mechanism, the stations allocate part of their TXOP to mobile users to transmit their uplink data. Because the downlink and uplink traffic flows have the same data rate, the ideal ratio of a station sharing TXOP between normal downlink transmission and reverse direction transmission should be 50%. This matches with the observed simulation results. According to the results, we conclude that bi-directional TXOP can enhance the uplink receiving throughput of the reverse direction initiator but may decrease the downlink sending throughput. As a result, reverse direction mechanism could provide better performance for applications with more symmetric bi-directional traffic.

### 5.5 Delay time

After above discussion on the effect on throughput of aggregation, block ACK, and reverse direction, we would like to further evaluate the packet delay time

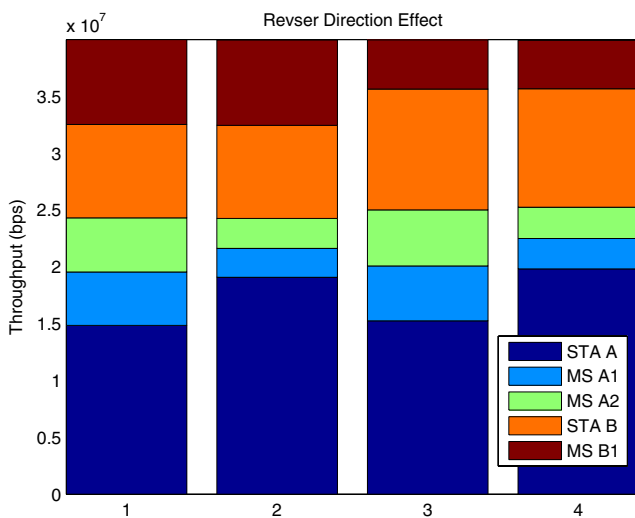

Fig. 11 Performance evaluation of reverse direction

with different combination of these features in 802.11n. In theory, aggregation and reverse direction should make some reduction on average packet delay time, and block ACK brings efficient error recovery when BER is high, but will introduce overheads in low BER. We still create 4 stations with CBR traffic to each other and define 6 schemes with different combination of support features: Aggregation, block ACK, and Reverse Direction mechanisms on Station 0. We measure the average receiving packet delay time of Node 0 in these schemes. For low BER schemes, the results are shown in Fig. 12.

We observe that aggregation mechanism can significantly reduce the average packet delay time, same as we saw in aggregation scenario simulation results. In addition, we also observe that the station with reverse direction mechanism can further reduce packet delay time comparing to those schemes without reverse direction. This is because reverse direction mechanism allows mobile users connected to the station transmitting their data in the station’s TXOP, which give mobile users more chance to upload their packet to the station, and the waiting time of each upload packet in queue can be shorten. On the other hand, we find out that block ACK mechanism slightly increase the packet delay time due to the overhead of extra size in block ACK. A more interesting thing we have observed is when the reverse direction mechanism are on, the gap between with and without block ACK becomes larger.

We also perform the simulation in high BER environment, and the results are shown in Fig. 13. We can see that when BER is high, block ACK mechanism can help reduce the delay time. This is because with block ACK mechanism the error recovery can be done

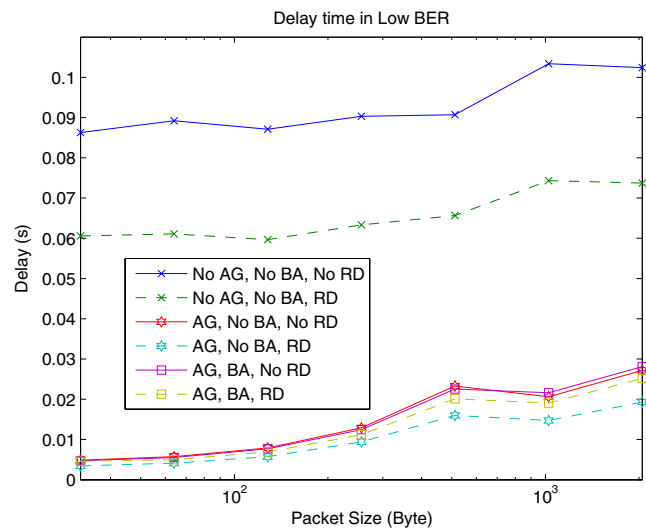
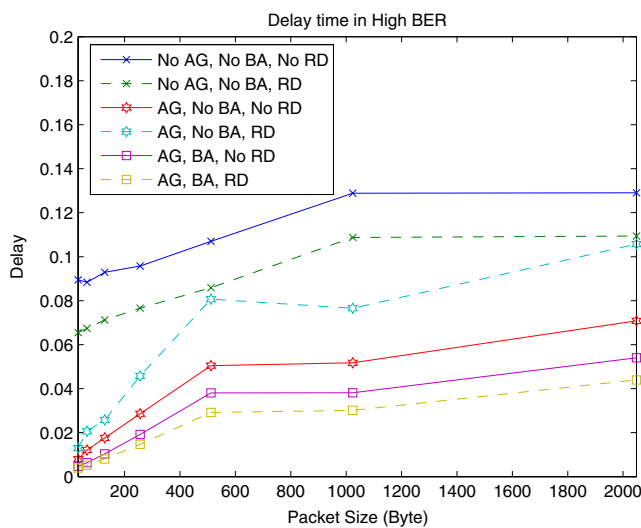

Fig. 12 Delay time in low BER scenario



**Fig. 13** Delay time in high BER scenario

more efficient and the delay time of retransmission of failure packet is shorten. However, the scheme with reverse direction but without block ACK is worse than the scheme without reverse direction. The reason is the high packet loss rate results more retransmission, and reverse direction mechanism induces more delay when numerous of retransmission is needed. But this is also solved by block ACK mechanism.

### 5.6 MIMO simulation

Although PHY layer is not the main topic of this paper, we also examine the performance of 802.11n under different MIMO system we have implemented. We use the same 4 node network setting with 25.6 Mbps CBR traffic and aggregation and block ACK mechanisms. We change the SNR by adjusting the distance between nodes. The results are shown in Fig. 14.

We observe that SM-STBC outperforms other MIMO systems with lower BER under every SNR. V-BLAST performs poorly that the total throughput reduce to 0 when SNR is below 17.5. From [4] we learned that SM-STBC has better performance when SNR greater than 8dB in outdoor environment, which means it is the best choice in short range 802.11n WLAN. SM-STBC has better performance when SNR is smaller or in indoor environment. However, these two MIMO systems have higher system complexity comparing to V-BLAST. Hybrid SM-STBC is introduced to leverage the high performance of SM-STBC and the low complexity of V-BLAST for practical MIMO system deployment.

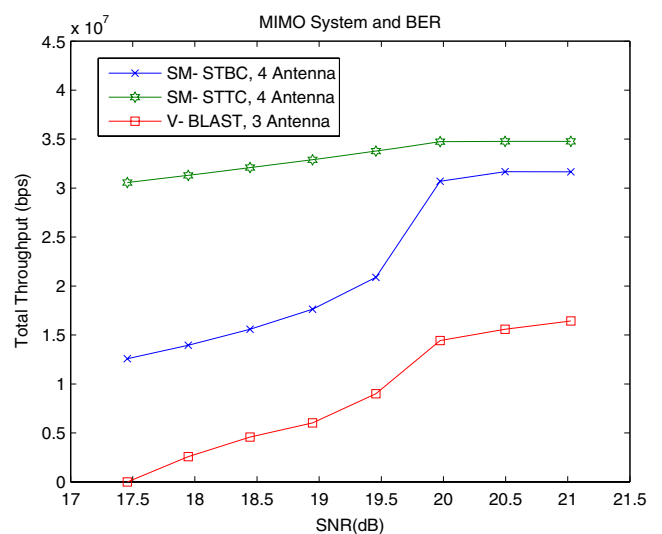

**Fig. 14** MIMO system

### 5.7 Overall measurement: VoIP R-score

After the discussion on the enhancement of each MAC feature in 802.11n, we will examine the overall IEEE 802.11n MAC enhancement from a practical viewpoint. Again we use the VoIP R-score as an objective performance measurement. We create a number of pairs of VoIP users communicating with G.711 voice codec. Every users is within transmission range of each other. The data rate of every user’s background traffic is 4 Mbps. Six schemes are evaluated:

1. MAC without Aggregation, block ACK, Reverse Direction is off (Legacy 802.11) (No AG, No BA, No RD)
2. MAC with Aggregation, without block ACK, Reverse Direction is off (AG, No BA, No RD)
3. MAC with Aggregation, block ACK, Reverse Direction is off (AG, BA, No RD)
4. MAC without Aggregation, block ACK, Reverse Direction is on (No AG, No BA, RD)
5. MAC with Aggregation, without block ACK, Reverse Direction is on (AG, No BA, RD)
6. MAC with Aggregation, block ACK, Reverse Direction is on (AG, BA, RD)

The VoIP simulation results in low BER scenario are shown in Fig. 15. When number of users increases, R-scores is decreased in every scheme. We observe that legacy 802.11 MAC has the lowest R-score throughout the whole simulation. Aggregation can significantly enhance R-score because of enhanced network

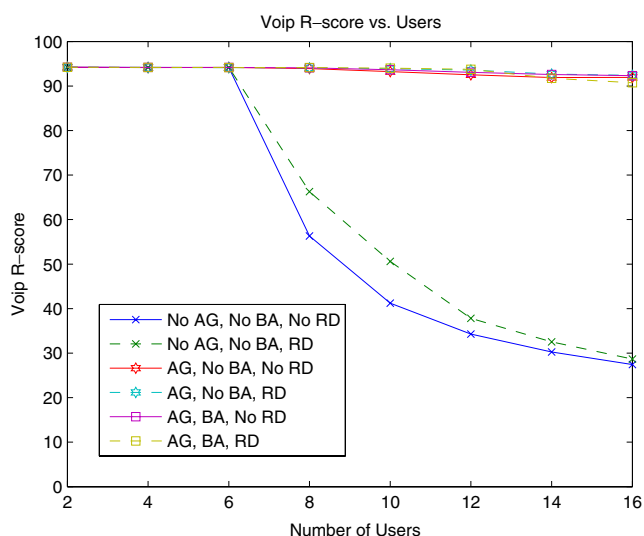

**Fig. 15** VoIP R-score in low BER

throughput. Although block ACK has more overhead in low BER scenario, the effect on R-score is neglectable. We also note that although reverse direction mechanism does not increase the total throughput, it can reduce the packet delay time by sharing the TXOP for the reverse direction VoIP flows; hence, it improves the R-score performance.

The VoIP simulation results in high BER scenario are shown in Fig. 16. We can see that the R-score of aggregation without block ACK mechanism significantly degrades due to the high packet loss rate. The performance is even worse than the legacy 802.11 MAC. On the other hand, we can see reverse direction can improve R-score. In addition, reverse direction mech-

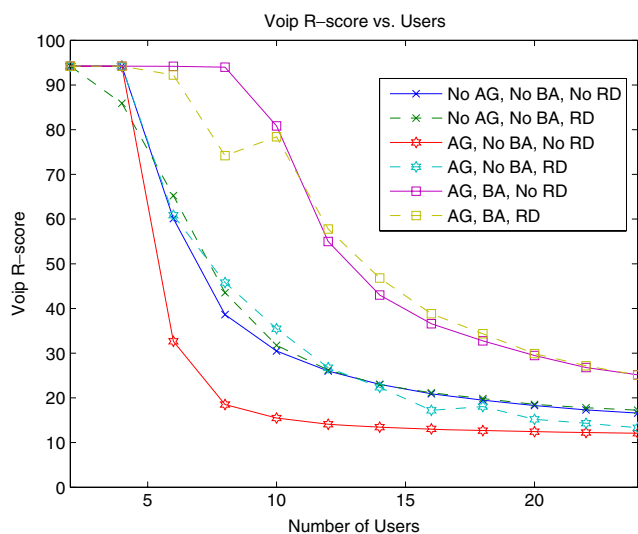

**Fig. 16** VoIP R-score in high BER

anism plays a significant role when block ACK mechanism is lacking. We observe that aggregation with block ACK mechanism is the effective design to support high quality VoIP service in high BER environment. From the overall simulation results, we can conclude that the overall enhancement from new features of 802.11n MAC protocol can significantly enhance the network performance and the quality of VoIP service.

## 6 Discussion

After evaluate the enhancement of IEEE 802.11n MAC layer design with simulation, we make further discussion on the application of each feature and the potential benefit of 802.11n enhancement on different type of network services. In current Internet, most packets (around 80%) are small-sized packets [14]. These small packets cause huge overheads in transmission and make a severe impact on WiFi networks. We can see this is a critical issue of legacy 802.11 protocol. Additionally, in the future Peer-to-Peer network (P2P), Voice over IP (VoIP), Video on Demand (VOD), and Online Gaming (OLG) will become the most popular services on the Internet. The common characteristic of these services is they produce large number of small packets in a burst time. We already showed that aggregation mechanism can reduce the overhead of small packets in 802.11 WiFi network. From Fig. 7, we observed that aggregation significantly enhances the throughput when the packet size is small. Aggregation is the key feature to handle the traffic while maintaining a reasonable throughput in the emerging Internet applications with small packet transmission. This enhancement can maintain the high voice quality of VoIP, as we observed in Fig. 8. Aggregation can also benefit the networking services like VOD and OLG as they all need high throughput transmission with small packet size.

Although aggregation mechanism can enhance the channel utilization in an interference-free wireless environment, the high packet error rate in practical wireless environment poses challenges to WLAN design. We have demonstrated this issue in Fig. 10. Aggregation may result in poorer performance than legacy 802.11 MAC protocol. In Fig. 10, we observed that Block ACK mechanism is necessary to overcome this wireless transmission challenge by efficiently retransmitting the incorrect MPDUs only. Although there is an additional overhead in block ACK bitmap, as we saw in Fig. 9, this mechanism prevents the drawbacks of aggregation in the error-prone wireless network. Block ACK mechanism is also effective in reducing packet delay

time, as we observed in Fig. 13. This can benefit delay-sensitive services like VoIP, and online gaming, as we have shown the quality of VoIP performance in Fig. 16. We conclude that the combination of aggregation and block ACK mechanism is capable for services with small packets in need of high throughput.

We evaluated the enhancement of reverse direction mechanism on the receiving throughput of RD initiator in Fig. 11 and delay time reduction in Figs. 12 and 13. We observed that reverse direction can help stations enhancing their performance by this bi-directional TXOP protocol. Moreover, there are an increasing number of interactive networking applications. An efficient bi-directional transmission technique is needed in the future wireless Internet. Even current networking services like VoIP and OLG also need a more efficient bi-directional network link in order to maintain high quality of service [1, 5]. The bi-directional TXOP protocol in reverse direction mechanism allows stations transmitting to each other through alternating two-way transmission. This station-to-station communication is more stable than uni-directional TXOP with channel contention protocol, and causes less delay time. We saw the enhancement on VoIP in Fig. 16 even without the aggregation mechanism. This mechanism is more useful in OLG because OLG usually needs quick response from user and have stricter requirement of uplink throughput. If the stations apply reverse direction mechanism, the uplink throughput can be enhanced as we observed in Fig. 11. However, this mechanism may not benefit the one-way network service like video streaming because the downlink throughput is reduced. Reverse direction mechanism could enhance network performance of bi-directional traffic applications with low delay requirements.

## 7 Conclusion

We have investigated the performance of IEEE 802.11n MAC protocol. The three enhanced 802.11n MAC mechanisms: aggregation, block acknowledgement and reverse direction have been discussed. We implemented an 802.11n module in NS-2 simulation platform with both MAC and PHY layer simulation. We designed several simulation scenarios to compare the performance of 802.11n and the legacy 802.11. The quality of VoIP service is significant better when transmitting over enhanced IEEE 802.11n. We showed that IEEE 802.11n indeed improves the channel efficiency and provides high quality WLAN networking support for VoIP service.

**Acknowledgement** This work was supported by the National Science Council of Taiwan under Grant NSC-97-2220-E-002-012-.

## References

1. Armitage GJ, Zander S (2004) Empirically measuring the QoS sensitivity of interactive online game players. In: ATNAC04: Australian Telecommunications Networks and Applications Conference, Sydney, December 2004
2. Cai LX, Ling X, Shen X, Mark JW, Cai L (2008) Supporting voice and video applications over IEEE 802.11n WLANs. *Wirel Netw*. doi:10.1007/s11276-007-0062-5
3. Cheng J, Wang H, Chen M, Cheng S (2001) Performance comparison and analysis between STTC and STBC. *IEEE Veh Technol Conf* 4:2487–2491
4. Chung J, Kim J, Kim T, Jo J (2004) Performance evaluation of MIMO-OFDM systems in correlated fading channels. *Can Conf Electr Comput Eng* 1:457–460
5. Cole RG, Rosenbluth JH (2001) Voice over IP performance monitoring. *SIGCOMM Comput Commun Rev* 31(2):9–24
6. Foschini GJ, Gans MJ (1998) On limits of wireless communications in a fading environment when Using Multiple antennas. *Wirel Pers Commun* 6(3):311–335
7. Li T, Ni Q, Turetli T, Xiao Y (2005) Performance analysis of the IEEE 802.11 e block ACK scheme in a noisy channel. In: 2nd International Conference on Broadband Networks, vol 1. Boston, October, pp 511–517
8. Lin Y, Wong VWS (2006) WSN01-1: frame aggregation and optimal frame size adaptation for IEEE 802.11n WLANs. *IEEE Global Telecommunications Conference*, San Francisco, December
9. Liu C, Stephens AP (2006) Delayed channel access for IEEE 802.11e based WLAN. *IEEE Int Conf Commun* 10:4811–4817
10. Mangold S, Choi S, Hiertz GR, Klein O, Walke B (2003) Analysis of IEEE 802.11e for QoS support in wireless LANs. *IEEE Wirel Commun* 10(6):40–50
11. McCanne S, Floyd S (2008) ns-2 network simulator. <http://www.isi.edu/nsnam/ns>
12. Ozdemir M, Gu D, McDonald AB, Zhang J (2006) Enhancing MAC performance with a reverse direction protocol for high-capacity wireless LANs. In: *IEEE 64th vehicular technology conference*, Montreal, September 2006
13. Papanagiotou I, Paschos GS, Kotsopoulos SA, Devetsikiotis M (2007) Extension and comparison of QoS-enabled Wi-Fi models in the presence of errors. In: *Global telecommunications conference*. Washington, DC, November, pp 2530–2535
14. Sinha R, Papadopoulos C, Heidemann J (2005) Internet packet size distributions: some observations. Technical report, October
15. Skordoulis D, Ni Q, Chen H-H, Stephens AP, Liu C, Jamalipour A (2008) IEEE 802.11n MAC frame aggregation mechanisms for next-generation high-throughput WLANs. *IEEE Wirel Commun* 15(1):40–47
16. Stephens A, Morioka Y, Adachi T, Akhmetov D, Shtin S (2006) TGn joint proposal MAC results, January
17. Wietholter S, Hoene C (2003) Design and verification of an IEEE 802.11 e EDCF simulation model in ns-2.26. Technische Universität at Berlin. Tech. Rep. TKN-03-019, November
18. Xiao Y (2005) IEEE 802.11n: enhancements for higher throughput in wireless LANs. *IEEE Wirel Commun* 12(6):82–91